



CST2466

2.1A H-Bridge Motor Driver

CST2466 DESCRIPTION

The CST2466 provides an integrated motor driver for cameras, consumer products, toys and other application with low-voltage or battery-powered motion control. The CST2466 can supply up to 2.1A of output DC current. It operates on a motor power supply (VM) from 2 to 11V and a device power supply voltage (VCC) of 2V to 6V. Ultra- low R_{DS-ON} allows SOP-8 package available. The CST2466 has a PWM (INA、INB) input interface. Full protections are integrated with over-current protection, under-voltage lockout and over-temperature shutdown.

CST2466 FEATURE

H-Bridge Motor Driver

- DC Motor or Other Loads
- Low On-Resistance :280mΩ
- 2.1-A Maximum DC Drive Current

Separate Motor and Logic Supply

- Motor VM : 2 to 11V
- Logic VCC : 2V to 6V

Low-Stand-by Current $\leq 2\mu A/VM=VCC=5V$

Small Package and Footprint

- 8-Pin ESOP with Thermal PAD

8-Pin SOP Protection Features

- VCC Under-voltage Lockout
- Over-Current Protection
- Thermal Shutdown

CST2466 APPLICATION

- Electric toothbrush, Electric lock
- Cameras
- DSLR Lenses
- Consumer Products
- Toys
- Robotics

CST2466 PIN DESCRIPTION

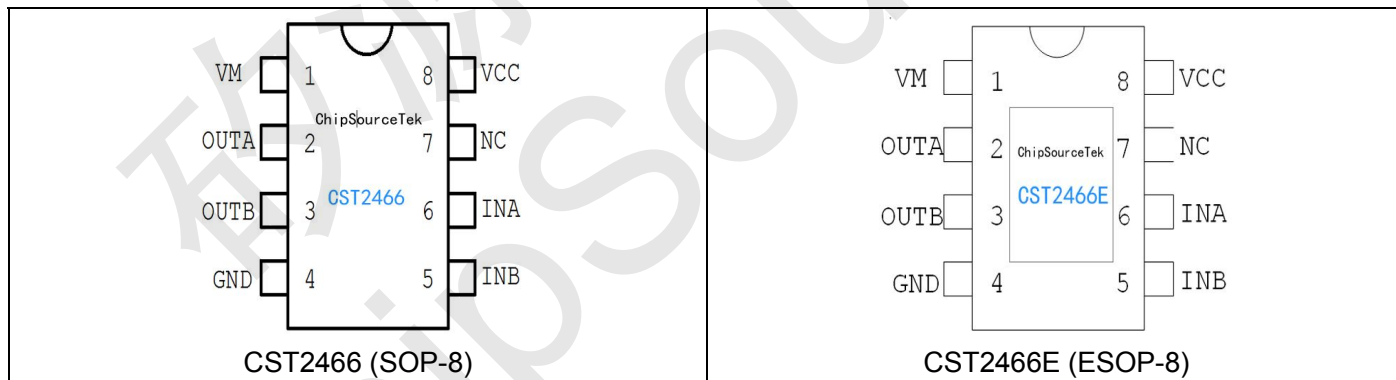

Pin number	Pin name	I/O	Description
1	VM	--	Motor power supply
2	OUTA	O	Motor drive output A
3	OUTB	O	Motor drive output B
4	GND	--	Ground
5	INB	I	Logic input B
6	INA	I	Logic input A
7	NC	--	No connection
8	VCC	--	Logic power supply



CST2466 BLOCK DIAGRAM

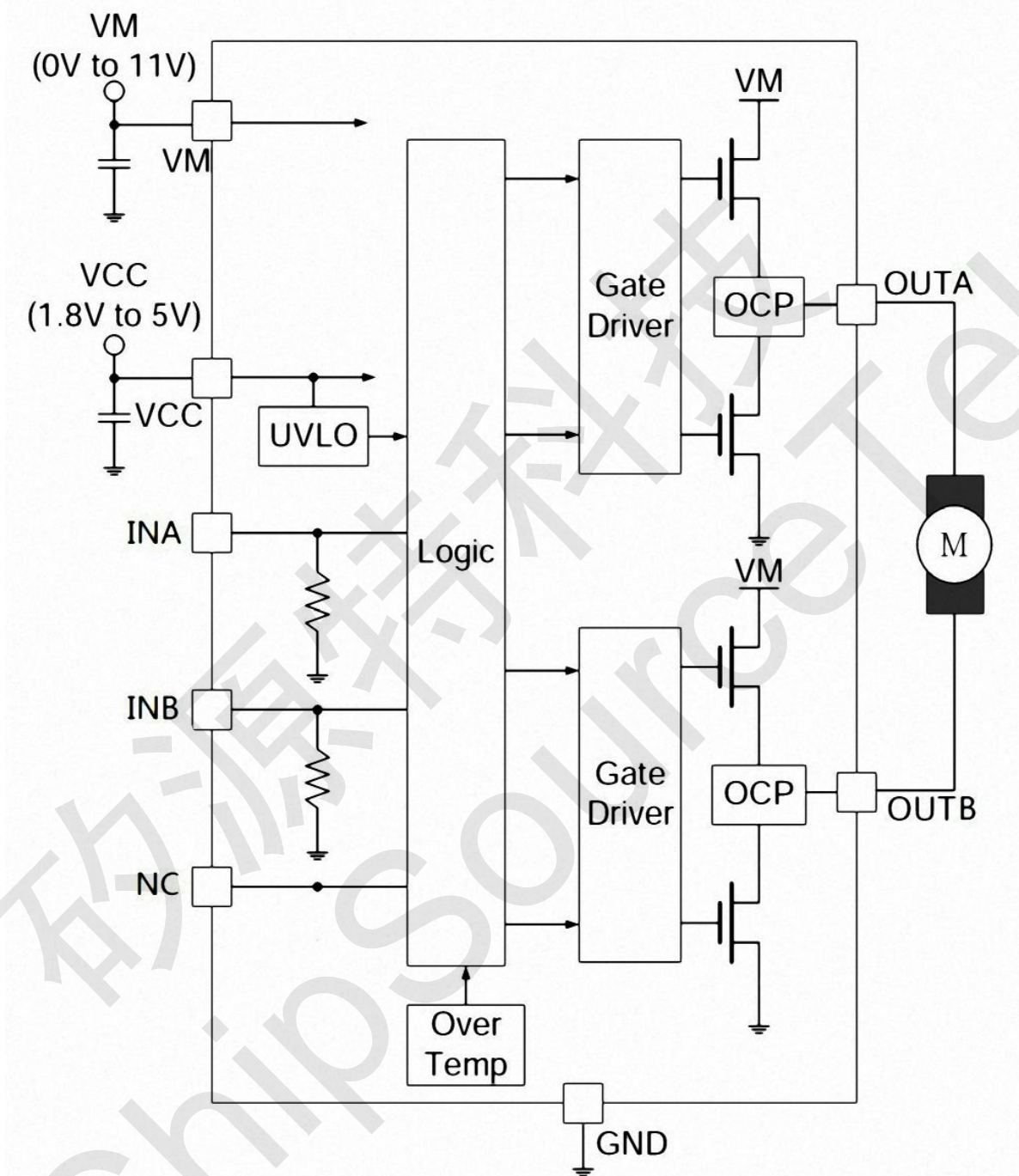



CST2466 ABSOLUTE MAXIMUM RATINGS

Parameters	Symbol		Value	Unit
Logic power supply voltage , VCC	VCC		7	V
Motor power supply voltage , VM	VM		11	V
Power dissipation	Pd	SOP-8	0.96	W
Operating Temperature, Top	Topr		-20~85	°C
Junction temperature	Tj		150	°C
Storage Temperature, Tstg	Tstg		-55~150	°C
Manual welding temperature			350~370	°C
Peak output current	Iop		3.5	A
Continuous Output Current	Ioc		2.1	A
PWM Frequency	f _{PWM}		33	KHz

CST2466 RECOMMENDED OPERATING CONDITIONS_(Ta=25°C)

Parameter	Symbol	Rating	Unit
Power supply voltage	VCC	2.0~6	V
Motor Power supply voltage	VM	9.6	V
High Input Voltage	VIN	0.5xVCC	V
Low Input Voltage	VIN	-0.8~0	V
Continuous Output Current	I _{OUT}	-1500~1500	mA

Note:The maximum continuous output current depends on the heat dissipation conditions. 2.1A(ESOP8)
1.68A(SOP8)

CST2466 ELECTRICAL CHARACTERISTICS

(Ta=25°C,VCC=3V,VM=6V,unless otherwise specified)

Parameter	Symbol	Test Condition	Min	Typ	Max	Unit
Overall Circuit						
Standby Current	I _{CCST}	INA=INB=GND	—	1	5	uA
Input control						
High Input Voltage	V _{INH}		2	4	6	V
Low Input Voltage	V _{INL}		—	—	0.8	V
PWM Drive Frequency	F _{PWM}		—	20	33	KHz
Reverse brake Time Required	R _{VBT}	from INA to INB or from INB to INA	200	500	—	uS



High Input Current	I_{INH}	$V_{IN}=3V$	—	250	400	μA
Low Input Current	I_{INL}	$V_{IN}=0V$	-1	0	—	μA
Pull Down Resistor	R_{IN}		—	12	—	$K\Omega$
Driving						
Output Impedance(HS+LS)	R_{ON}	$I_o=\pm 200mA$	—	0.26	0.6	Ω
Protection Circuits						
Thermal shutdown temperature	T_{TSD}	Die temperature	—	150	—	$^{\circ}C$

CST2466 INPUT AND OUTPUT TRUTH TABLE

Input		Output		Function
INA	INB	OUTA	OUTB	
L	L	Hi-Z	Hi-Z	Stand-by(Stop)
H	L	H	L	A CH output
L	H	L	H	B CH output
H	H	L	L	Brake

CST2466 OUTPUT AND INPUT WAVEFORM

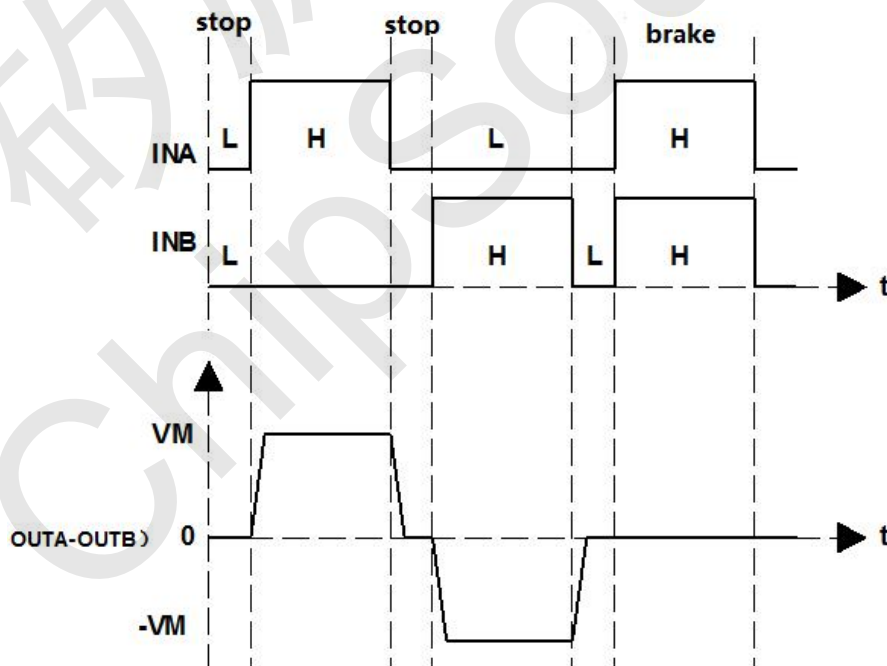

Note: Least Reverse Brake Time Required recommended: 200 μ S.



CST2466 POWER SUPPLY RECOMMENDATION

Having appropriate local bulk capacitance is an important factor in motor-drive system design. It is generally beneficial to have more bulk capacitance.

The amount of local bulk capacitor needed depends on the following factors ,

- The highest current required by the motor system.
- The power-supply capacitance and ability to source current
- The amount of parasitic inductance between the power supply and motor system
- The acceptable voltage ripple
- The type of motor used (brushed DC motor, brushless DC motor, stepper motor)
- The motor braking method

The inductance between the power supply and motor drive system limits the rate at which current can change from the power supply. If the local bulk capacitance is too small, the system responds to excessive current demands or dumps from the motor with a change in voltage. When adequate bulk capacitance is used, the motor voltage remains stable and high current can be quickly supplied.

The voltage rating for bulk capacitors should be higher than the operating voltage, to provide margin for cases when the motor transfers energy to supply.

CST2466 PCB LAYOUT GUIDANCE

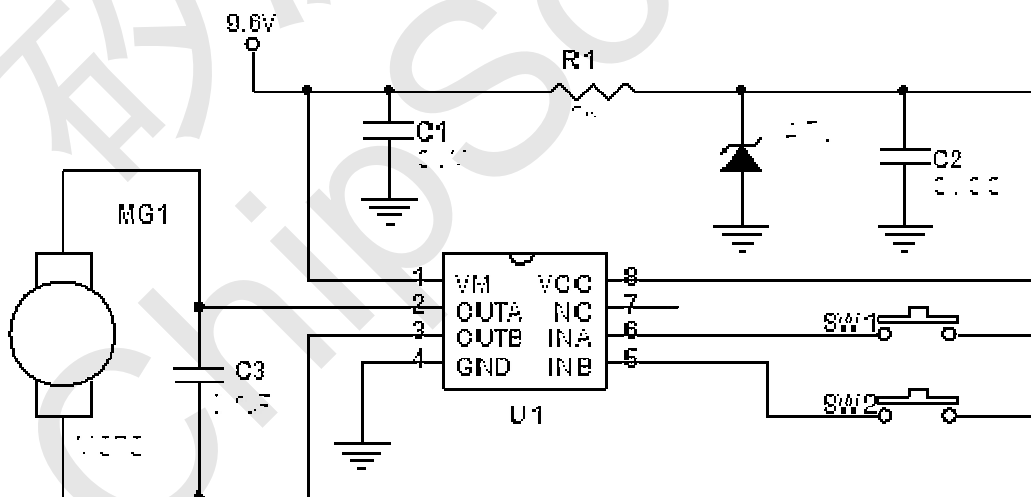

Test Circuit

The capacitor C1 connected between the GND and the VM pins must be located as close as possible to the CST2466 chip. In different applications, C1 (shown as above) is recommended to use a 0.1uF in 3V applications; a 1uF is recommended for 4.5V applications; a 4.7uF is recommended for 6V applications; in 9.6V applications, it is recommended to use 22uF, all these capacitors should be SMD package. The



connection between the negative pole of the capacitor and the GND terminal of the IC should be as short as possible. That is to say, the line route should not far away.

When the application board has capacitors while filtering for other chips that is far away from the CST2466, it need to place a small capacitor for CST2466.

The capacitor C3 preferably soldering to the motor poles instead of placing it on the PCB. When it is inconvenient to soldering on the motor poles, it can be mount on the PCB. The following diagram is the PCB layout reference .

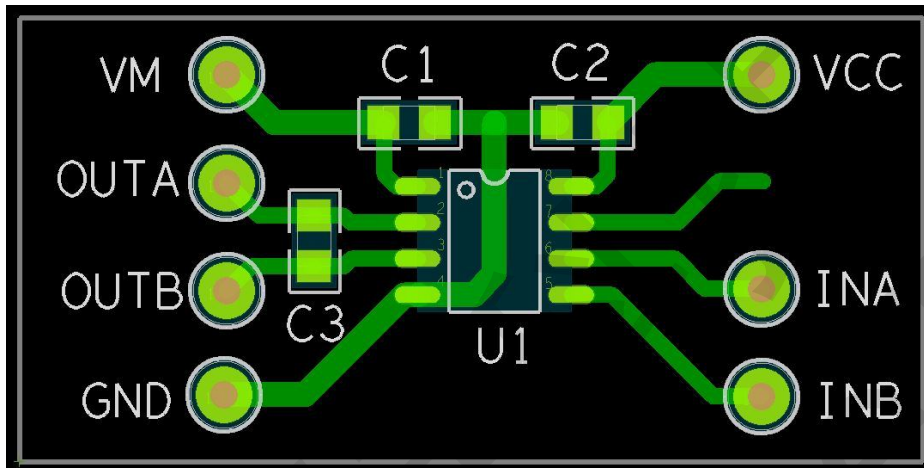

CST2466 PACKAGE DIMENSION

CST2466 ESOP-8 (E2=2mm;D1=3mm)

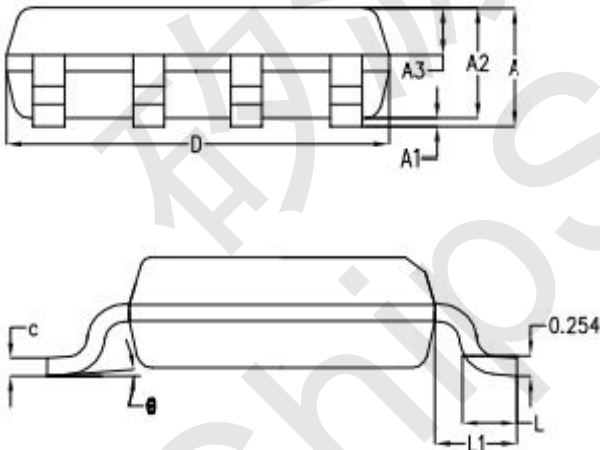

SYMBOL	MILLIMETER		
	MIN	NOM	MAX
A	-	1.50	1.55
A1	-	0.10	0.15
A2	1.35	1.40	1.45
A3	0.55	0.60	0.65
b	0.35	0.40	0.45
c	0.17	0.22	0.25
D	4.85	4.90	4.95
E	5.90	6.00	6.10
E1	3.80	3.90	4.00
e	1.27BSC		
L	0.60	0.65	0.70
L1	1.05BSC		
θ	0°	4°	6°

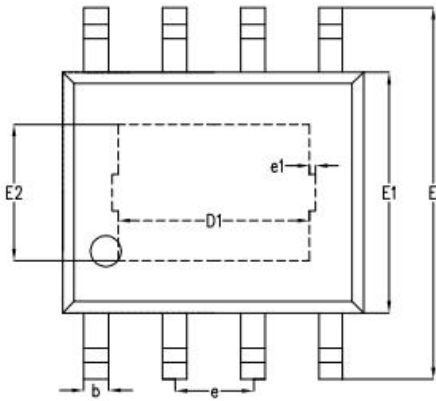

CST2466 SOP-8

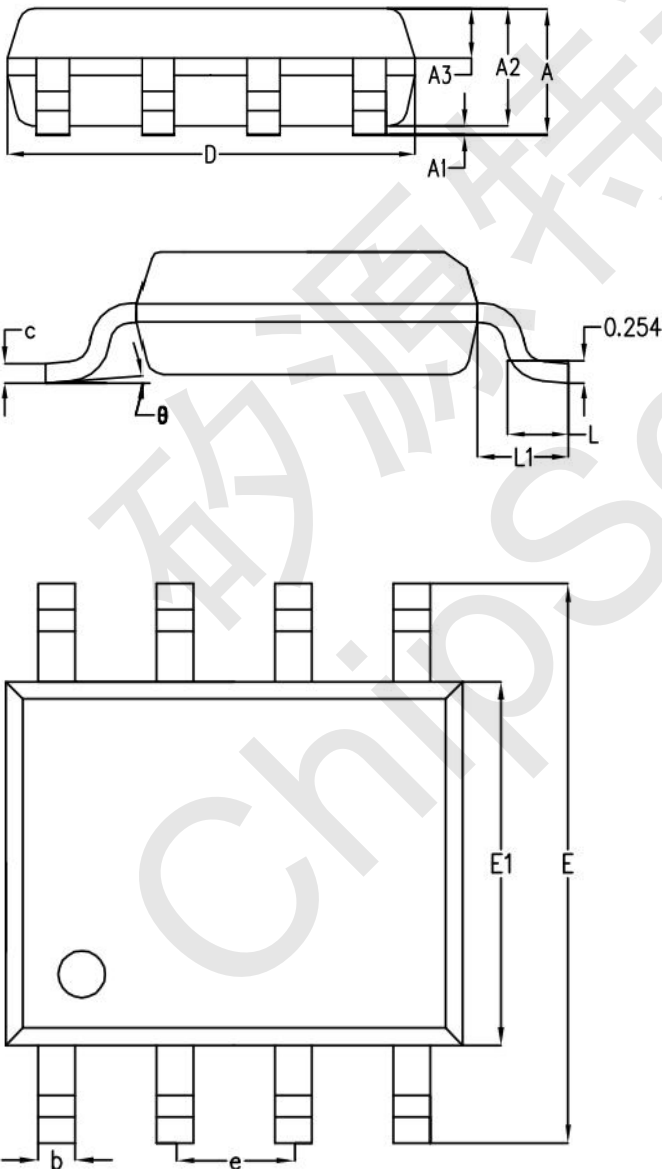

SYMBOL	MILLIMETER		
	MIN	NOM	MAX
A	-	1.50	1.55
A1	-	0.10	0.15
A2	1.35	1.40	1.45
A3	0.55	0.60	0.65
b	0.35	0.40	0.45
c	0.17	0.22	0.25
D	4.85	4.90	4.95
E	5.90	6.00	6.10
E1	3.80	3.90	4.00
e	1.27BSC		
L	0.60	0.65	0.70
L1	1.05BSC		
θ	0°	4°	6°