



## 150 mA, high input voltage LDO Linear Regulators ME6208 Series

### General Description

ME6208 series are low-dropout linear voltage regulators with a built-in voltage reference module, error correction module and phase compensation module. ME6208 series are based on the CMOS process and allow high voltage input with low quiescent current. This series has the function of internal feedback resistor setting from 3.0V to 5.0V. The output accuracy is  $\pm 2\%$ .

### Typical Application

- Electronic weighbridge
- SCM
- Phones, cordless phones
- Security Products
- Water meters, power meters

### Features

- High output accuracy:  $\pm 2\%$
- Input voltage: up to 18 V
- Output voltage: 3.0 V ~ 5.0V
- Ultra-low quiescent current (Typ. = 3  $\mu$  A)
- Output Current:  $I_{out} = 200\text{mA}$   
(When  $V_{in} = 7\text{V}$  and  $V_{out} = 5\text{V}$ )
- Importation good stability: Typ. 0.05% / V
- Low temperature coefficient
- Ceramic capacitor can be used

### Package

- 3-pin SOT23-3, SOT89-3, TO92

### Typical Application Circuit

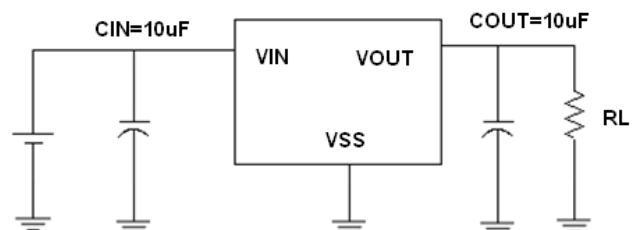



## Selection Guide

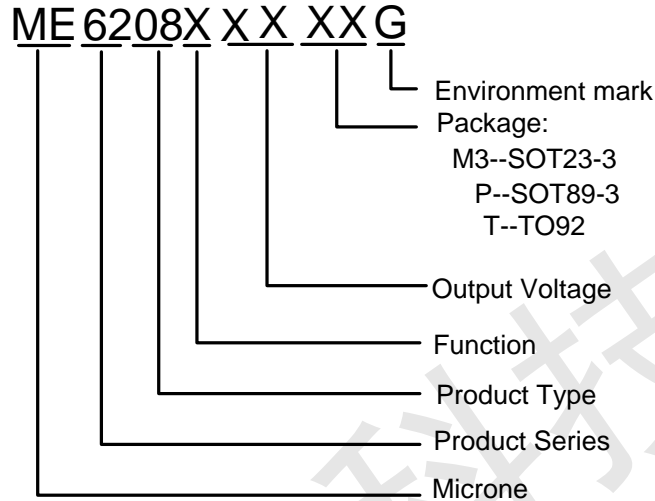

product series	product description
ME6208A21M3G	$V_{OUT} = 2.1V$ ; Package: M3,P,T
ME6208A30M3G	$V_{OUT} = 3.0V$ ; Package: M3,P,T
ME6208A33M3G	$V_{OUT} = 3.3V$ ; Package: M3,P,T
ME6208A36M3G	$V_{OUT} = 3.6V$ ; Package: M3,P,T
ME6208A40M3G	$V_{OUT} = 4.0V$ ; Package: M3,P,T
ME6208A44M3G	$V_{OUT} = 4.4V$ ; Package: M3,P,T
ME6208A50M3G	$V_{OUT} = 5.0V$ ; Package: M3,P,T



## Pin Configuration

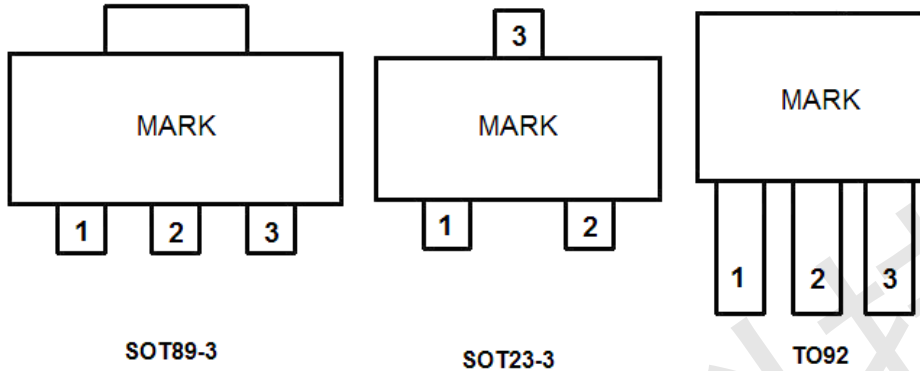

## Pin Assignment

Pin Number		Pin Name	Functions
SOT89-3 / TO92	SOT23-3		
1	1	$V_{SS}$	Ground
2	3	$V_{IN}$	Power Input
3	2	$V_{OUT}$	Output

## Block Diagram

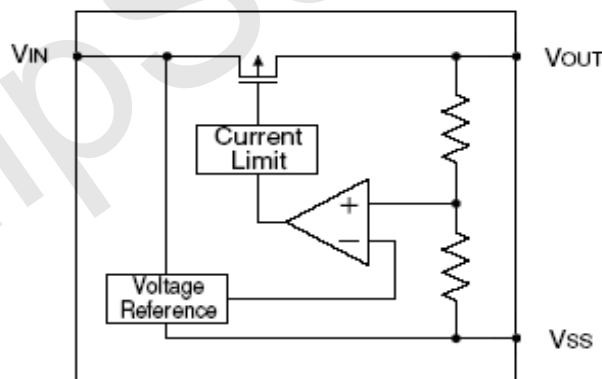



### Absolute Maximum Ratings

Parameter	Symbol	Ratings	Units	
Input Voltage	$V_{IN}$	18	V	
Output Current	$I_{OUT}$	250	mA	
Output Voltage	$V_{OUT}$	$V_{SS}-0.3 \sim V_{IN} +0.3$	V	
Power Dissipation	SOT89-3	$P_D$	500	mW
	TO92		500	mW
	SOT23-3		300	mW
Operating Temperature Range	$T_{OPR}$	$-45 \sim +150$	$^{\circ}C$	
Storage Temperature Range	$T_{STG}$	$-55 \sim +150$	$^{\circ}C$	
Lead Temperature		$260^{\circ}C, 10sec$		

### Electrical Characteristics

( $V_{IN} = V_{OUT} + 2.0V$ ,  $C_{IN} = C_L = 10\mu F$ ,  $T_a = 25^{\circ}C$ , unless otherwise noted)

Parameter	Symbol	Conditions	Min.	Typ.	Max.	Units
Output Voltage	$V_{OUT(E)}$ (Note 2)	$I_{OUT} = 40mA$ , $V_{IN} = V_{OUT} + 2V$	X 0.98	$V_{OUT(T)}$ (Note 1)	X 1.02	V
Input Voltage	$V_{IN}$				18	V
Maximum Output Current	$I_{OUT\_max}$	$V_{IN} = V_{OUT} + 2V$	150			mA
Load Regulation	$\Delta V_{OUT}$	$V_{IN} = V_{OUT} + 2V$ , $1mA \leq I_{OUT} \leq 100mA$		10		mV
Dropout Voltage (Note 3)	$V_{dif1}$	$I_{OUT} = 50mA$		250		mV
	$V_{dif2}$	$I_{OUT} = 100mA$		500		mV
	$V_{dif3}$	$I_{OUT} = 200mA$		1000		mV
Supply Current	$I_{SS}$	$V_{IN} = V_{OUT} + 2V$		3	4	$\mu A$
Line Regulations	$\frac{\Delta V_{OUT}}{\Delta V_{IN} \times V_{OUT}}$	$I_{OUT} = 40mA$ $V_{OUT} + 2V \leq V_{IN} \leq 18V$		0.05		%/V

Note :

- $V_{OUT(T)}$  : Specified Output Voltage
- $V_{OUT(E)}$  : Effective Output Voltage ( ie. The output voltage when " $V_{OUT(T)} + 2.0V$ " is provided at the Vin pin while maintaining a certain  $I_{OUT}$  value.)
- $V_{DIF}$ :  $V_{IN1} - V_{OUT(E)}$   
 $V_{IN1}$  : The input voltage when  $V_{OUT(E)}$  appears as input voltage is gradually decreased.  
 $V_{OUT(E)}$  = A voltage equal to 98% of the output voltage whenever an amply stabilized  $I_{OUT}$  and  $\{V_{OUT(T)} + 2.0V\}$  is input.



### Precautions

- During the test, if AC/DC power supply and the ceramic chip capacitors collocation is used, there may be serious voltage spike phenomenon instantaneously. When the power supply access to 16V, the voltage is rushed to about 30V instantaneously. Because of exceeding the limit voltage of chip, the chip is damaged. If you string a small resistance of 1 ohm in the input end during the test, the peak phenomenon can be avoided.
- In the test, there is serious burr phenomenon only when the AC/DC power is used with ceramic chip capacitors. But electrolytic capacitors and tantalum capacitance won't appear above phenomenon. Please be sure to pay attention to this point when you use AC/DC power.
- In normal use, when any type of capacitor is used with battery or the supply of fire power, the above phenomenon doesn't occur.

### Type Characteristics

(1) Output Current VS. Output Voltage (  $T_a = 25\text{ }^\circ\text{C}$  )

ME6208A50

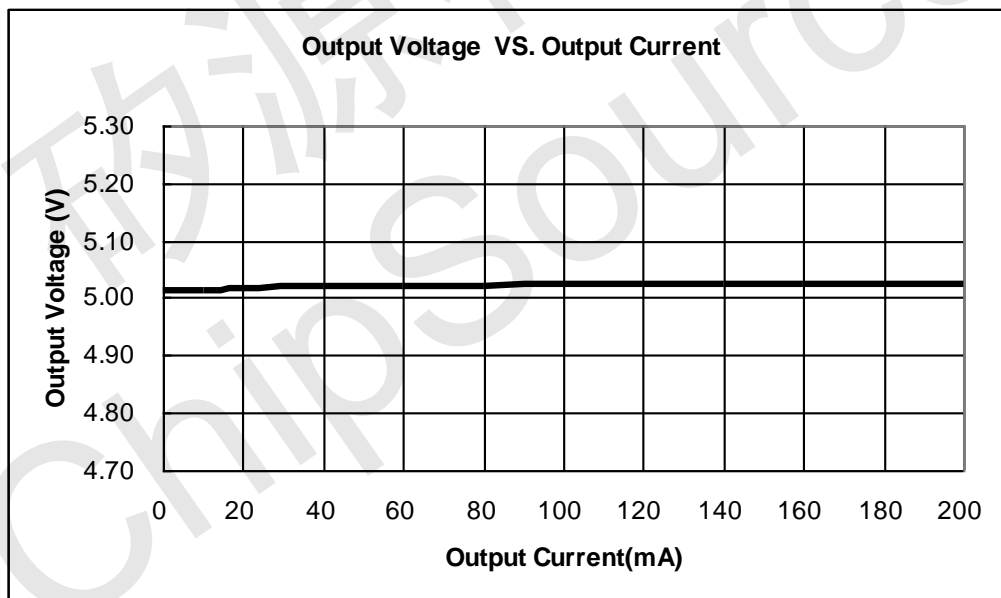



(2) Input Voltage VS. Output Voltage ( $T_a = 25^\circ\text{C}$ )

ME6208A50

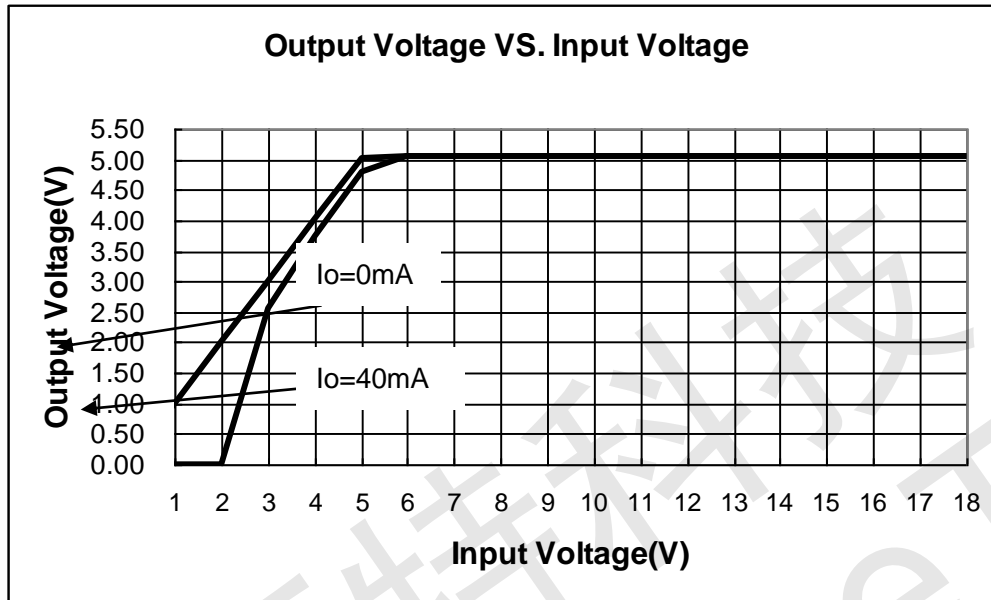

(3) Output Current VS. Dropout Voltage ( $T_a = 25^\circ\text{C}$ )

ME6208A50

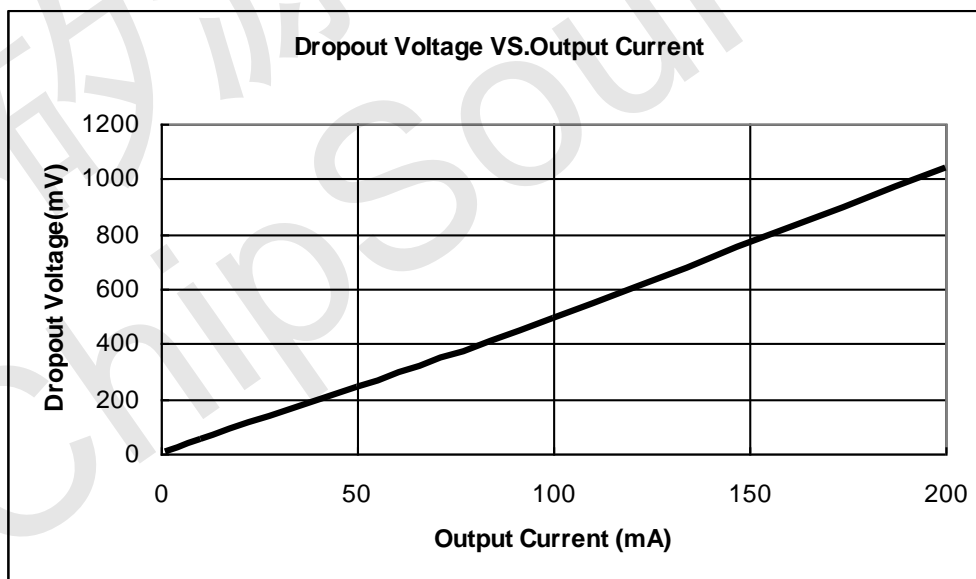



(4) Input Voltage VS. Supply Current ( $T_a = 25^\circ\text{C}$ )

ME6208A50

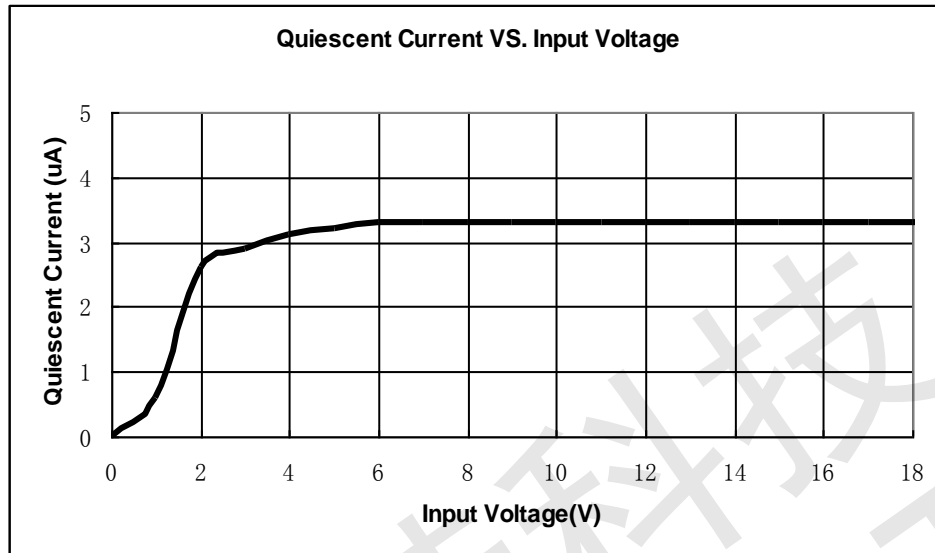

(5) Output Voltage VS. Temperature

ME6208A33PG

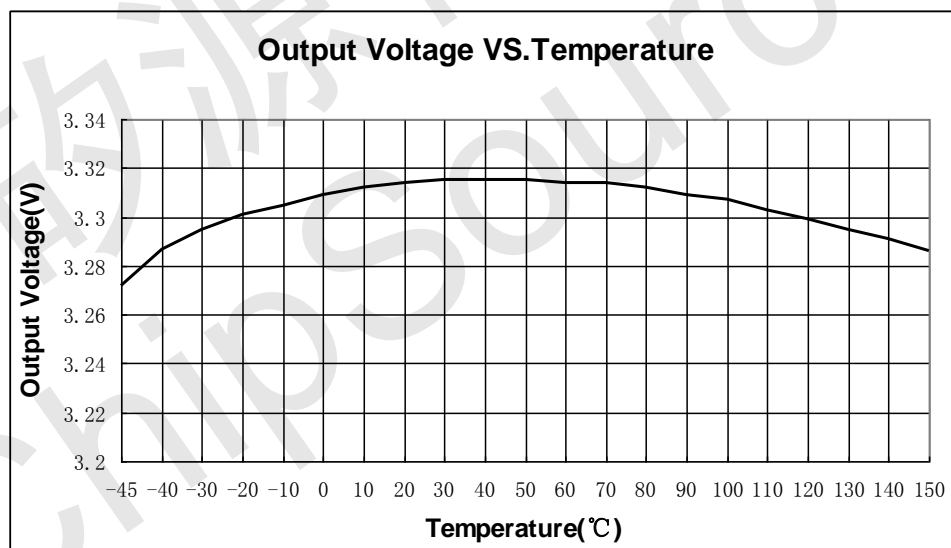





## Packaging Information

- Packaging Type: SOT23-3

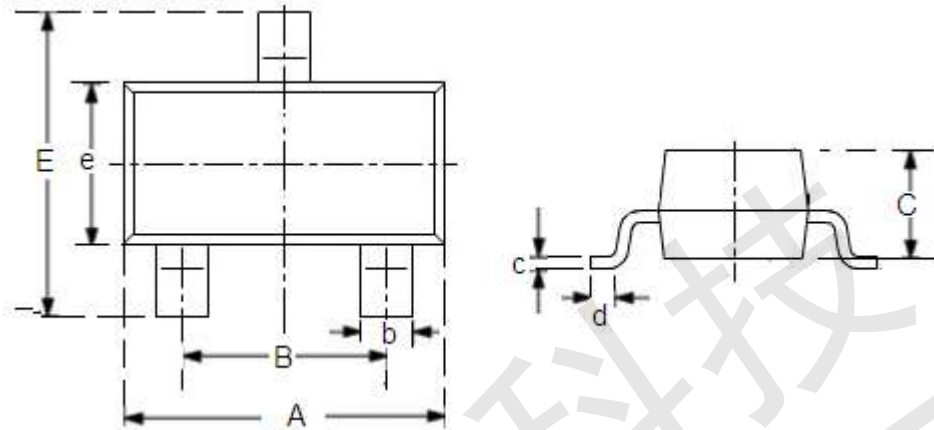

DIM	Millimeters		Inches	
	Min	Max	Min	Max
A	2.7	3.1	0.1063	0.122
B	1.7	2.1	0.0669	0.0827
b	0.35	0.5	0.0138	0.0197
C	1.0	1.2	0.0394	0.0472
c	0.1	0.25	0.0039	0.0098
d	0.2	-	0.0079	-
E	2.6	3.0	0.1023	0.1181
e	1.5	1.8	0.059	0.0708





● Packaging Type: SOT89-3

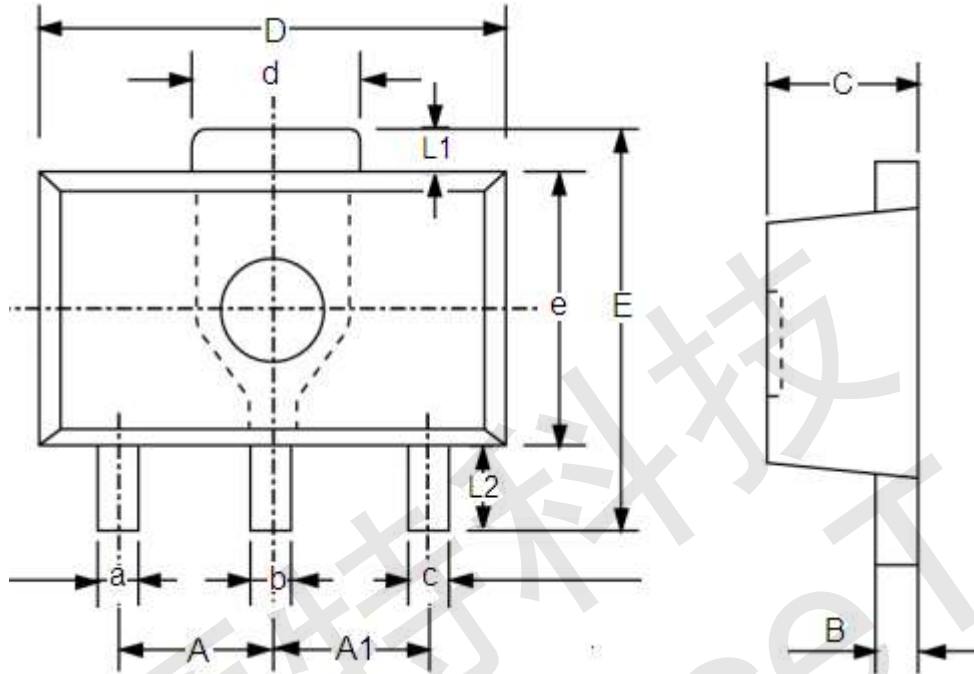

DIM	Millimeters		Inches	
	Min	Max	Min	Max
A	1.4	1.6	0.0551	0.0630
A1	1.4	1.6	0.0551	0.0630
a	0.36	0.48	0.0142	0.0189
b	0.41	0.53	0.0161	0.0209
c	0.36	0.48	0.0142	0.0189
d	1.4	1.75	0.0551	0.0689
B	0.38	0.43	0.015	0.0169
C	1.4	1.6	0.0551	0.0630
D	4.4	4.6	0.1732	0.181
E	-	4.25	-	0.1673
e	2.4	2.6	0.0945	0.1023
L1	0.4	-	0.0157	-
L2	0.8	-	0.0315	-



● Packaging Type:TO-92

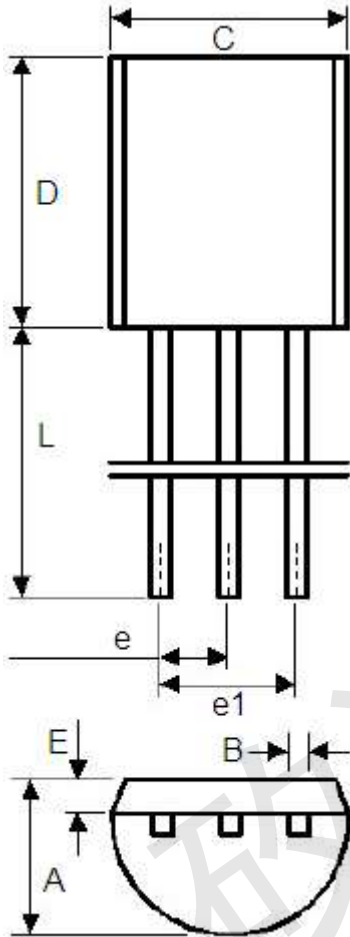

	Min	Max	Min	Max
A	3.4	3.8	0.13386	0.1496
B	0.3	0.5	0.0118	0.0197
C	4.4	4.8	0.1732	0.189
D	4.4	4.8	0.1732	0.189
E	0.9	1.5	0.0354	0.059
e	1.17	1.37	0.046	0.0539
e1	2.39	2.69	0.094	0.1059
L	12	16	0.4724	0.6299



- The information described herein is subject to change without notice.
- ShenZhen ChipSourceTek Technology Co.,Ltd. is not responsible for any problems caused by circuits or diagrams described herein whose related industrial properties, patents, or other rights belong to third parties. The application circuit examples explain typical applications of the products, and do not guarantee the success of any specific mass-production design.
- Use of the information described herein for other purposes and/or reproduction or copying without the express permission of ShenZhen ChipSourceTek Technology Co.,Ltd. is strictly prohibited.
- The products described herein cannot be used as part of any device or equipment affecting the human body, such as exercise equipment, medical equipment, security systems, gas equipment, or any apparatus installed in airplanes and other vehicles, without prior written permission of ShenZhen ChipSourceTek Technology Co.,Ltd..
- Although ShenZhen ChipSourceTek Technology Co.,Ltd. exerts the greatest possible effort to ensure high quality and reliability, the failure or malfunction of semiconductor products may occur. The user of these products should therefore give thorough consideration to safety design, including redundancy, fire-prevention measures, and malfunction prevention, to prevent any accidents, fires, or community damage that may ensue.